

# EZCHEM™

Automated Distribution System for Bulk Chemistry



- SUPPORTS WASHER DISINFECTORS, INSTRUMENT WASHERS, ULTRASONICS, CART WASHERS, AND MORE
- INDIVIDUAL BULK CHEMICAL TANK CAN SUPPLY UP TO 6 WASHERS
- REMOTE CHEMICAL DISTRIBUTION FROM 250 FT AWAY
- CLOSED LOOP CHEMICAL DISPENSING



SCAN FOR PRODUCT VIDEO

The EZCHEM is the industry's first plug-n-play distribution system for bulk chemistry. EZCHEM can supply instrument cleaning, drying and lubrication chemistries to any washer disinfectors, instrument washers, ultrasonic washers, cart washers, and more. The system utilizes industry recognized Knight peristaltic pumps and controller with a patent pending auto-filling EZChem reservoir to eliminate the handling and transport of harsh chemical concentrates. The modular design of the EZCHEM allows the system to readily adapt to your chemical distribution requirements.

[www.KnightHC.com](http://www.KnightHC.com)

**KNIGHT**® 

WE MAKE INSTRUMENT CLEANING EASY™

# EZCHEM™

*The EZChem system minimizes chemical waste, eliminates washer down time, eliminates handling of harsh chemical concentrates, and improves workplace safety.*

## STROBE/AUDIBLE ALARM

- ✓ Eliminates washer down time
- ✓ Alerts the CS technician to the low level condition of the bulk chemical containers

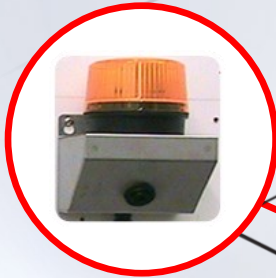

## EZCHEM RESERVOIR

- ✓ Eliminates manual handling of chemical concentrates
- ✓ Auto-filling chemical supply reservoir with a 1 gallon capacity



## EZCHEM REMOTE

- ✓ Displays system error codes for troubleshooting



## EZCHEM CONTROLLER AND PERISTALTIC PUMPS

- ✓ Eliminates the manual transport of chemical concentrates to remote locations
- ✓ Pumps the chemistry from bulk chemical containers to the EZChem reservoirs



## EZSEAL PICKUP ASSEMBLY

- ✓ Prevents chemical contamination
- ✓ Prevents contact of harsh chemical concentrates with end users
- ✓ Minimizes chemical waste

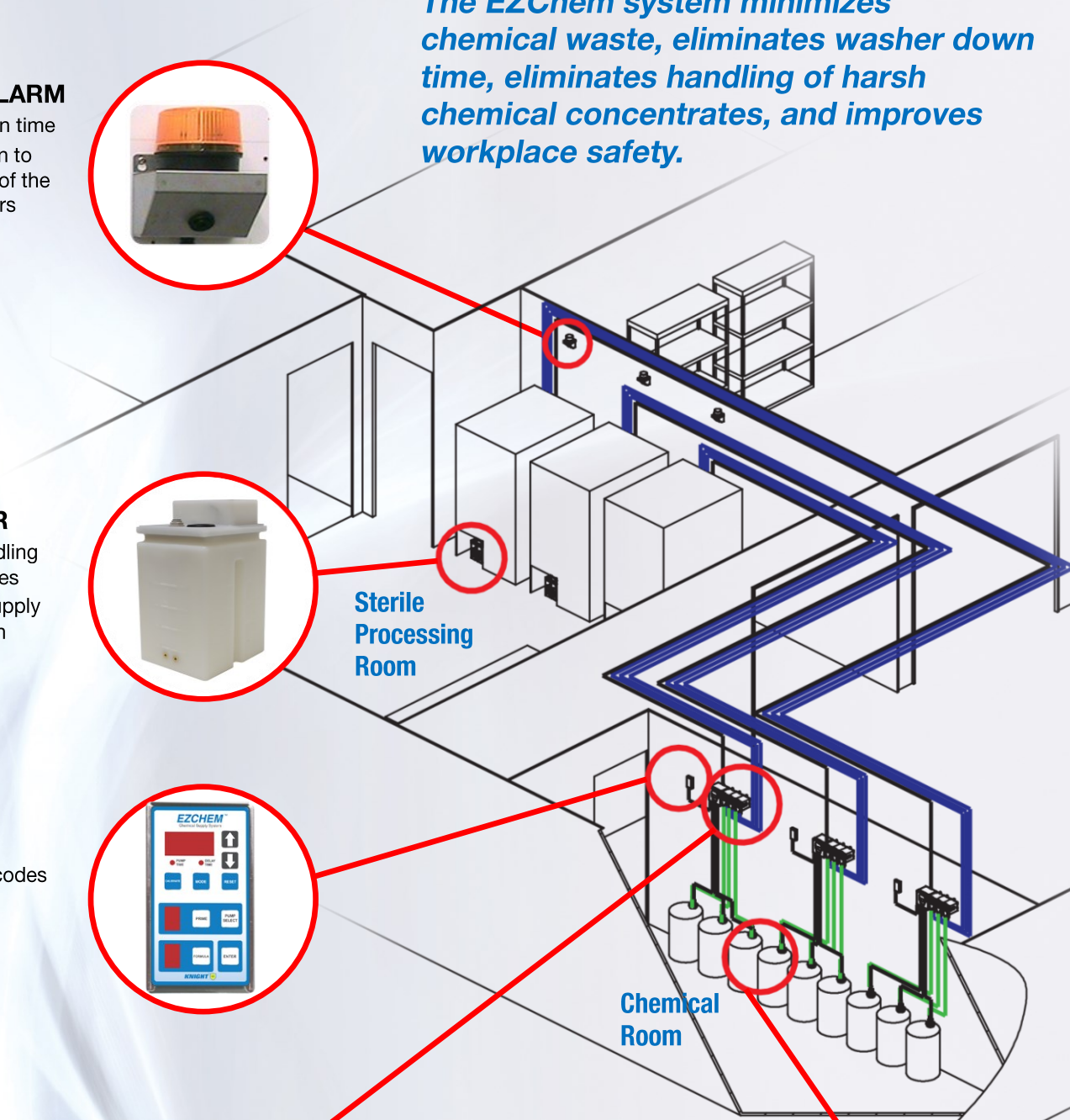

## PLUG-N-PLAY INSTALLATION

- NO modification to the washer disinfectors, uses the existing washer disinfectant pumps and controls for chemical dosing
- NO wiring of interface to washer disinfectors
- NO 510K recertification needed for washer disinfectors
- Tool-less, twist-lock communication connections
- System is factory set to run right out of the box without additional programming
- Automated self-priming system

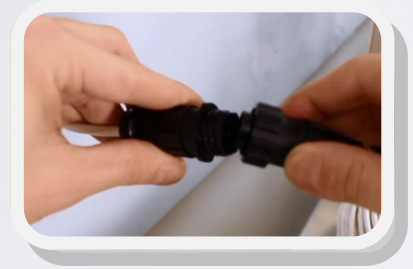

## AVAILABLE IN 1 TO 3 PUMP SYSTEMS

- 36 oz/min (1 liter) peristaltic pump flow rate
- Modular pumps and control unit
- Proven Knight peristaltic pump technology
- Plenum rated fire retardant tubing material
- Long life pump tubes for instrument cleaning chemistries



## ONE BULK CHEMICAL TANK CAN FEED UP TO 6 RESERVOIRS, YOU NEED 1 PERISTALTIC PUMP PER RESERVOIR

Supply chemistries to washer disinfectors, Instrument washers, ultrasonic washers, cart washers from up to 250 feet away (max 25psi).

- Supply chemistry from individual supply containers
- Supply chemistry from bulk tanks with supply headers



# EZCHEM™

## LOW LEVEL DETECTION SYSTEM

Low chemical level detection for various container sizes can be accomplished with our alarm system. The external strobe alarm warn operators when chemicals are in low supply.

- 20" probe (.5 m) fits 5–10 gal/liter containers
- 30" probe (.75 m) fits 10–30 gal containers
- 43" Probe (1.1 m) fits 30–55 gal containers



## PLUMBING/ELECTRICAL DIAGRAM

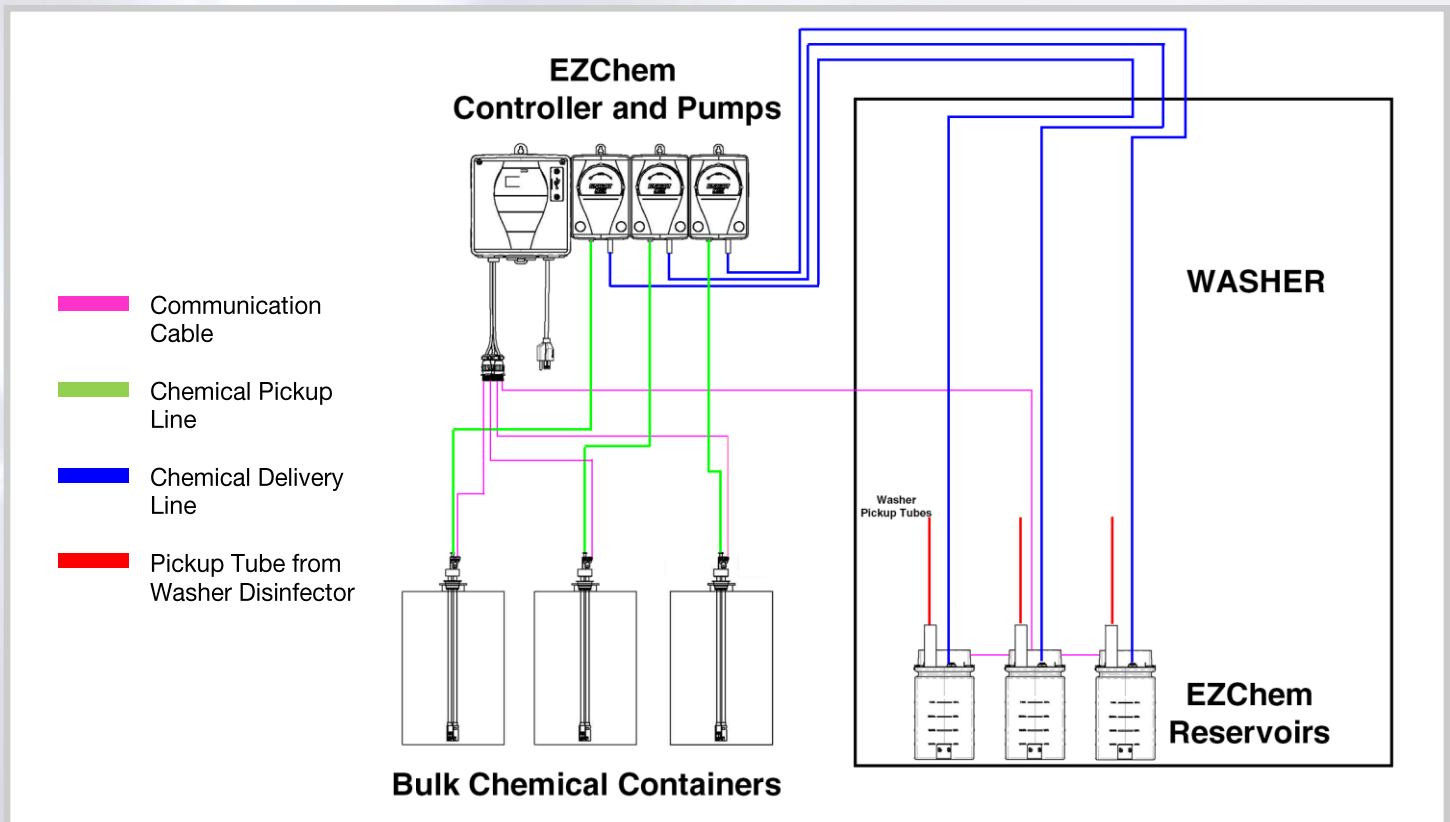

**Knight LLC Headquarters**  
15340 Barranca Parkway  
Irvine, CA 92618 USA  
www.KnightHC.com

**Knight Europe**  
Tel +44 (1273) 402-780  
Fax +44 (1273) 402-781

**Knight USA**  
Tel (949) 595-4816  
Fax (949) 595-4801

**Knight Canada**  
Tel (905) 542-2333  
Fax (905) 542-1536

AUTHORIZED KNIGHT HC DISTRIBUTOR